

ES20 SERIES

High Security Electric Strikes - Australian Footprint

PRODUCT DIMENSIONS

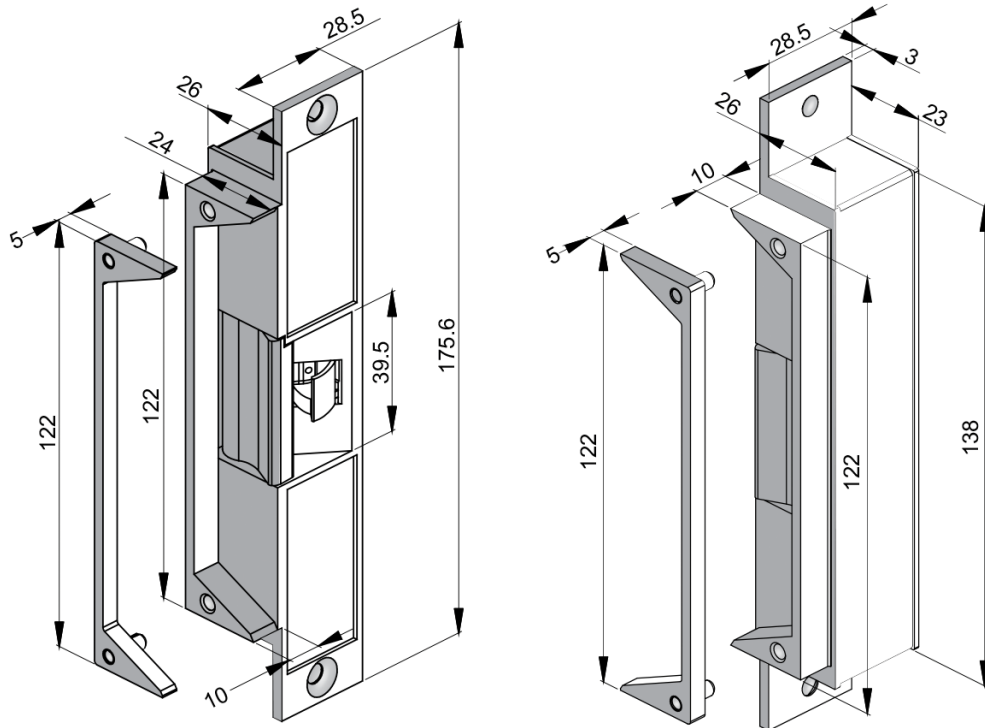

Dimensions (mm)

ES20 FACTS

- 5 year warranty
- Simple Power To Lock/Power To Release interchange
- No loose pins and springs
- 10mm strike lip pre-drilled for extension lips
- Multi-Voltage: 10-30VDC
- Fire rated CE & RCM Approvals
- Superior holding strength

ACCESSORIES



ES20-EL15

LOX ES20 EXTENSION LIP 15MM

ES20-EL25

LOX ES20 EXTENSION LIP 25MM

ES20-EL50

LOX ES20 EXTENSION LIP 50MM

ES20-EL75

LOX ES20 EXTENSION LIP 75MM



ES20REBATE

LOX ES20 STAINLESS STEEL 13MM REBATE KIT

LOX
LOCKING

LOX LOCKING PTY LTD | www.loxlocking.com.au

LOX[®]