

ES10 SERIES

Light Commercial and Residential Electric Strikes - ANSI Footprint

PRODUCT DIMENSIONS

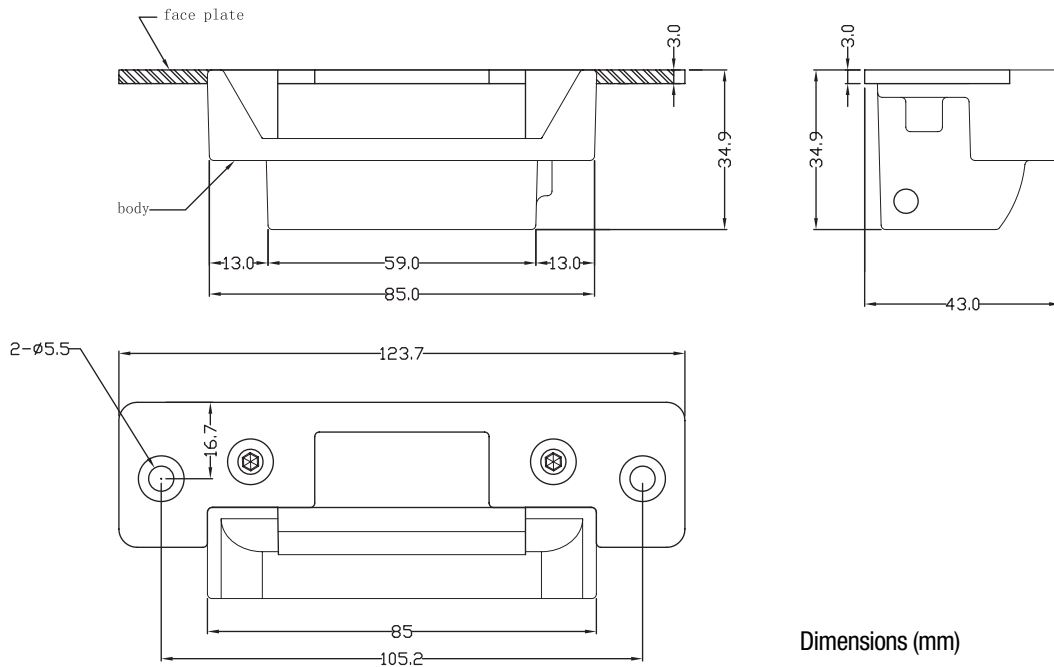

Dimensions (mm)

ES10 FACTS

- ES10 Weather Resistant (IP56)
- ES10M monitored version available (not weather resistant)
- 5 year warranty
- Simple Power To Lock/Power To Release interchange
- Pre-drilled for extension lips
- Dual-Voltage: 12 or 24VDC
- Fire rated

ACCESSORIES



ES10-EL15

LOX ES10 EXTENSION LIP 15MM

ES10-EL25

LOX ES10 EXTENSION LIP 25MM

ES10-EL50

LOX ES10 EXTENSION LIP 50MM

ES10-EL75

LOX ES10 EXTENSION LIP 75MM

LOX
LOCKING

LOX LOCKING PTY LTD | www.loxlocking.com.au

LOX[®]