

RG80

Weatherproof Lock

The RG80 is the foremost high-strength lock designed for securing gates, roller doors, shipping containers and any other commercial door or entry way.

Designed with weatherproofing as one of its critical features the RG80 offers an impressive IP67 weather rating an E-coated aluminium lock body and strike for excellent corrosion resistance and a built-in heater for continued functionality in extreme cold environments.

With full monitoring outputs including tamper proof detection along with user configurable control settings, the RG80 is the perfect indoor and outdoor locking solution.

Features

- Fail safe/Fail secure
- Variable voltage 12 to 24VDC
- Low current consumption (Heater OFF)
- IP67 weather rating
- 3 user selectable control methods
- Multiple relock attempts to lock or unlock
- Built in heater for extreme cold environments
- Bolt locked & unlocked monitoring
- Door position monitoring
- Anti-tamper detection monitoring

Typical applications

- Security gates
- Roller doors
- Cold storage rooms
- Shipping containers
- Commercial doors



Specifications

Door Gap	15mm Maximum
Static strength	50'000 newtons (5000kgs)
Dynamic strength	200 Joules
Weather rating	IP67
Cycle tested	300'000 cycles
Voltage	12-24VDC
Voltage tolerance	+/-15%
Current draw	
Standby	40mA/12VDC, 30mA/24VDC
Maximum:	1.0A/12VDC, 0.5A/24VDC
Heater On (24VDC only):	2.0A/24VDC
Monitors Switches	24VDC, 025A
Operating temperature	-35°C ~ +70°C
Operating Mode	Fail Secure/Fail Secure
Material	
Lock/Strike Body	Aluminium 383
Bolt Pin	Stainless steel 304
Strike Ring	UV Stabilized ABS

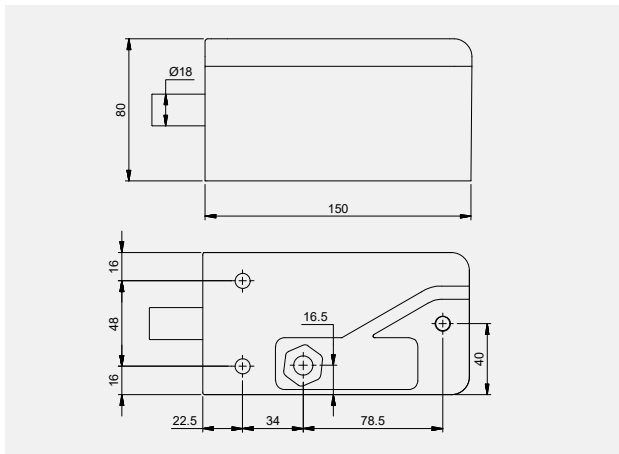

Dimensions - Lock

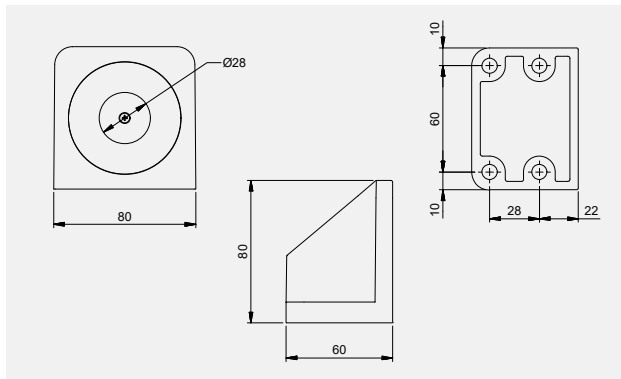

Dimensions - Strike

Specialty Locks

Item	Article Number	Description
RG80	9400000007060	RG80 LOCK & STRIKE 12-24VDC IP67 RATED
RG303A	9400000007059	STRIKE ONLY SUIT RG80