

KML-5000G

Electromagnetic Gate Lock

The KML-5000G is a surface mounted electromagnetic gate lock which can be used on single, double doors and gates.

It has a holding force of 540KGS and dual voltage with lock sensor. It also features a built-in voltage spike suppressor and is C-Tick, UL Listed and CE approved.

Features

- Surface mounted - single door, double swing doors, sliding doors and gates
- Built-in voltage spike suppressor
- Lock sensor (hall effect IC)
- Multiple fixing (standard) - face fix and underside
- Weather proof rating - IP65



Specifications

Lock	203L x 63W x 40D(mm)
Armature plate	185L x 61W x 16T(mm)
Holding Force	5,400N (540Kg)
Voltage	12/24VDC
Current draw	500mA/12VDC, 250mA/24VDC
Material	Stainless Steel Housing Weather proof rated IP65

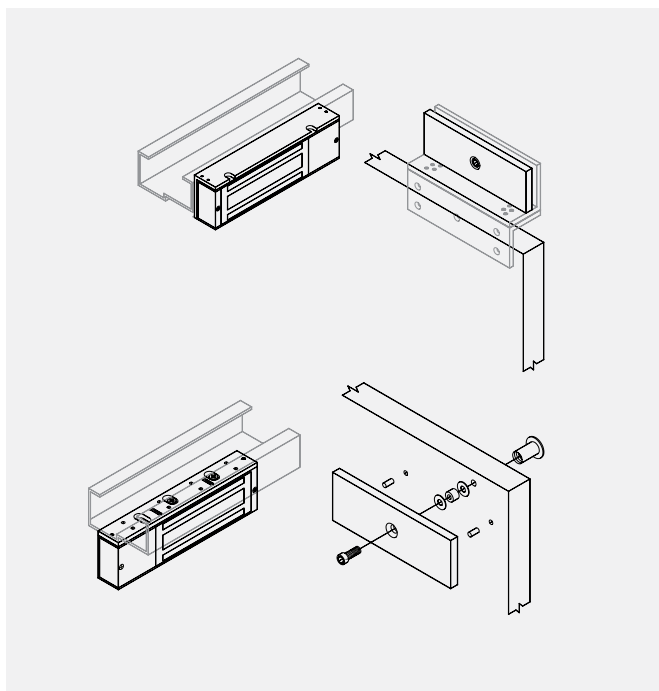

Typical Installation

Item	Article Number	Description
KML-5000G	9400000002517	KML-5000G EML 540KG GATE LOCK IP65