

KML-2

Morticed Type Electromagnetic Lock

The KML-2 is a morticed type electromagnetic lock which can be used on single and double sliding doors.

It has a holding force 270KGS and dual voltage with both lock and door sensor. It also features a built-in voltage spike suppressor and is C-Tick, UL Listed and CE approved.

Features

- Mortised Type - single door, sliding door and double action door
- Built-in voltage spike suppressor
- Door status sensor (reed switch)
- Anti Residual magnetism device (ARM)



Specifications

Lock	228L x 38W x 27D(mm)
Armature plate	185L x 38W x 12.5T(mm)
Holding Force	2,700N (270Kg)
Voltage	12/24VDC
Current draw	500mA/12VDC, 250mA/24VDC
Material	Brushed anodized aluminium housing Zinc plated steel armature

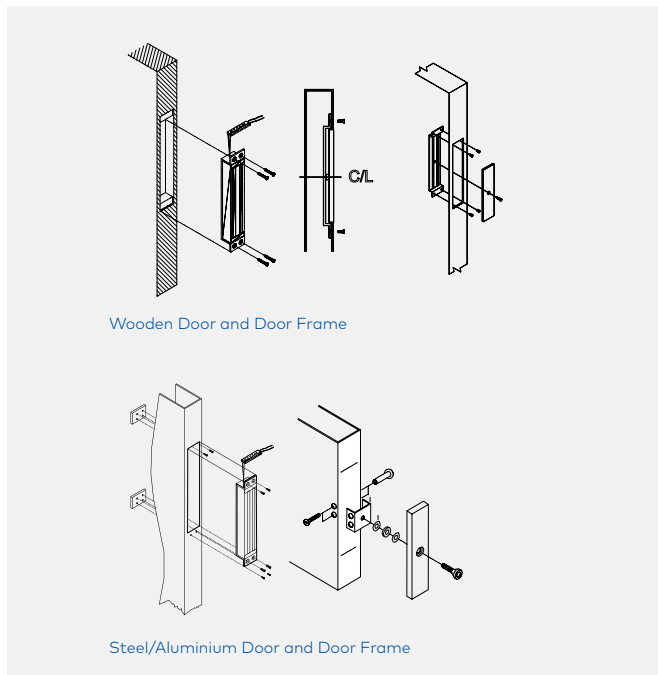

Wooden Door and Door Frame

Steel/Aluminium Door and Door Frame

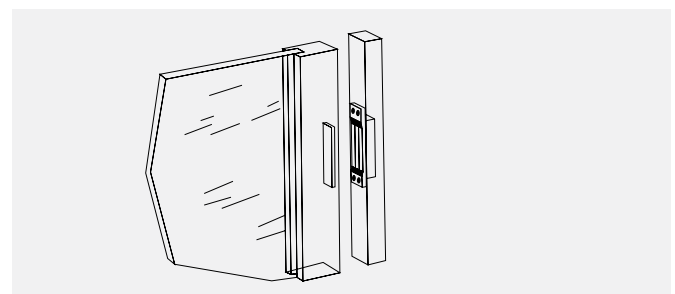

Installation Positions - Double Doors

Typical Installation

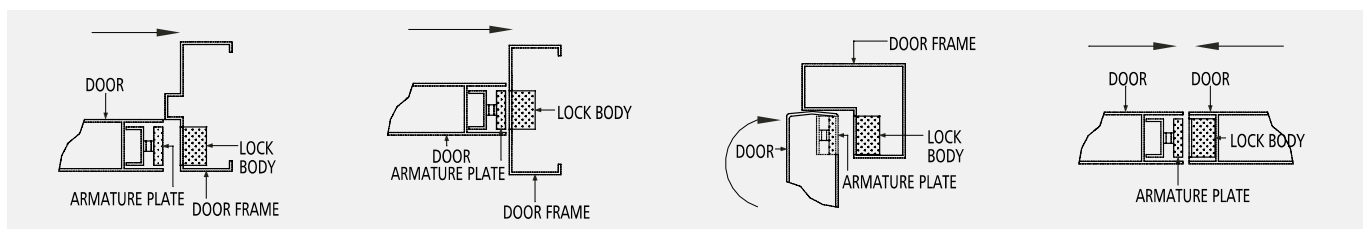

Applications

Item	Article Number	Description
KML-2	940000002515	KML-2 EML 270KG MORTISE SGL/SLIDE/DBL

Electromagnetic