



CSD-1226 (12V26Ah) *AUS* CELL No. 1



CSD-1226 is a general purpose 12V 26Ah sealed lead acid (SLA) battery with a 5 year floating design life that meets both IEC and JIS standards. Suitable for a wide range of domestic and commercial applications such as Mobility, UPS, Fire and Security systems.

Specification

Cells Per Unit	6
Voltage Per Unit	12
Capacity	26Ah@20hr-rate to 1.75V per cell @25°C
Weight	Approx. 8.10 Kg
Max. Discharge Current	260 A (5 sec)
Internal Resistance	Approx. 10 mΩ
Operating Temperature Range	Discharge: -20°C~60°C Charge: 0°C~50°C Storage: -20°C~60°C
Normal Operating Temperature Range	25°C ±5°C
Float charging Voltage	13.7 to 13.9 VDC/unit Average at 25°C
Recommended Maximum Charging Current Limit	7.8 A
Equalization and Cycle Service	14.6 to 14.8 VDC/unit Average at 25°C
Self Discharge	Valve Regulated Lead Acid (VRLA) batteries can be stored for more than 6 months at 25°C. Self-discharge ratio less than 3% per month at 25°C. Please charge batteries before using.
Terminal	Faston F3/F13
Container Material	A.B.S. (UL94-HB), Flammability resistance of UL94-V2 can be available upon request.



MH28539



G4M20206-0910-E-16



ISO9001:2000 Certificate

Dimensions

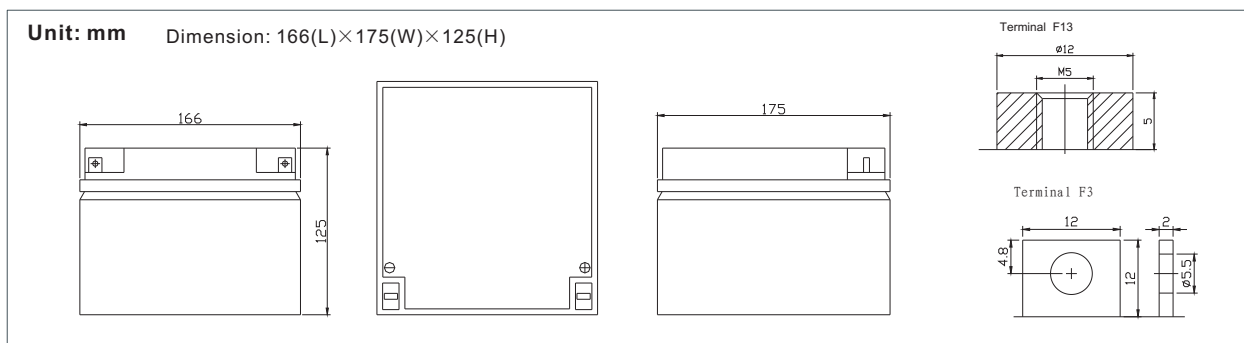

Constant Current Discharge Characteristics : A(25°C)

F.V/Time	5MIN	10MIN	15MIN	30MIN	1HR	2HR	3HR	4HR	5HR	8HR	10HR	20HR
9.60V	100.4	66.54	52.16	29.89	17.85	10.28	7.093	5.591	4.643	3.002	2.599	1.459
10.0V	96.81	64.88	50.49	29.51	17.36	10.07	6.962	5.513	4.565	2.990	2.572	1.406
10.2V	91.12	61.67	49.08	29.05	17.20	9.97	6.900	5.459	4.515	2.963	2.533	1.380
10.5V	81.91	57.66	46.30	28.25	16.86	9.84	6.838	5.406	4.460	2.937	2.520	1.339
10.8V	73.39	53.78	43.68	27.32	16.56	9.76	6.759	5.380	4.413	2.925	2.478	1.260
11.1V	64.21	49.30	40.30	26.28	16.11	9.36	6.626	5.333	4.368	2.901	2.440	1.240

Constant Power Discharge Characteristics : W(25°C)

F.V/Time	5MIN	10MIN	15MIN	30MIN	1HR	2HR	3HR	4HR	5HR	8HR	10HR	20HR
9.60V	1057	707.7	558.4	342.1	207.3	119.9	81.66	66.16	54.96	35.95	31.14	17.48
10.0V	1029	693.1	550.4	338.6	204.2	118.9	81.50	66.00	54.68	35.81	30.84	16.86
10.2V	978.8	665.6	543.1	335.7	202.7	118.2	81.19	65.46	54.15	35.54	30.55	16.55
10.5V	893.4	638.2	514.8	328.8	200.0	117.2	80.86	64.86	53.51	35.24	30.23	16.08
10.8V	806.0	597.0	486.4	321.0	196.7	116.2	79.92	64.62	52.95	35.09	29.77	15.15
11.1V	710.8	555.8	458.1	312.2	193.0	112.2	78.35	63.97	52.45	34.84	29.33	14.91

All mentioned values are average values.

Effect of temperature on long term float life

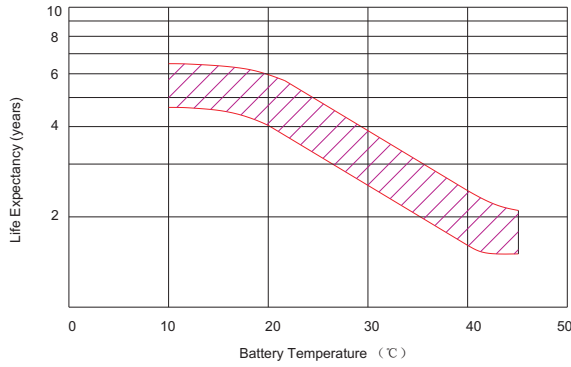

Storage characteristic

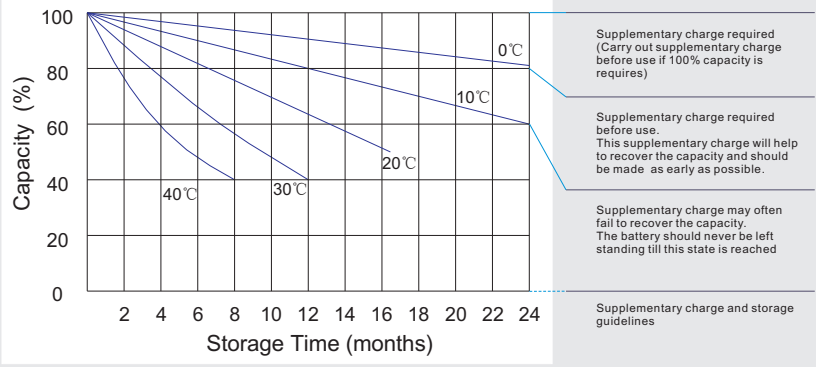

Charge characteristic Curve for standby use

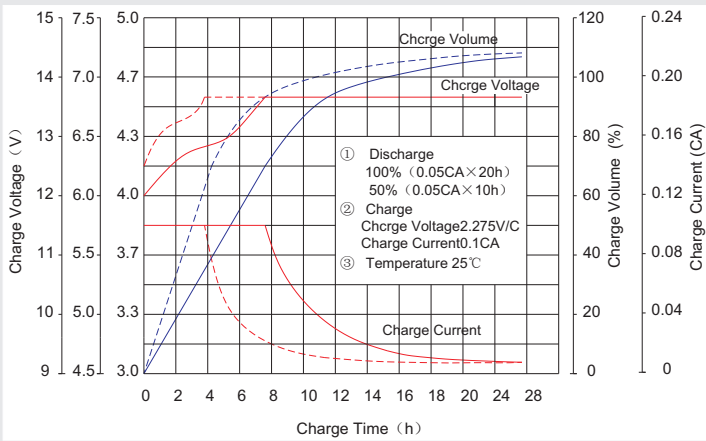

Discharge characteristic Curve

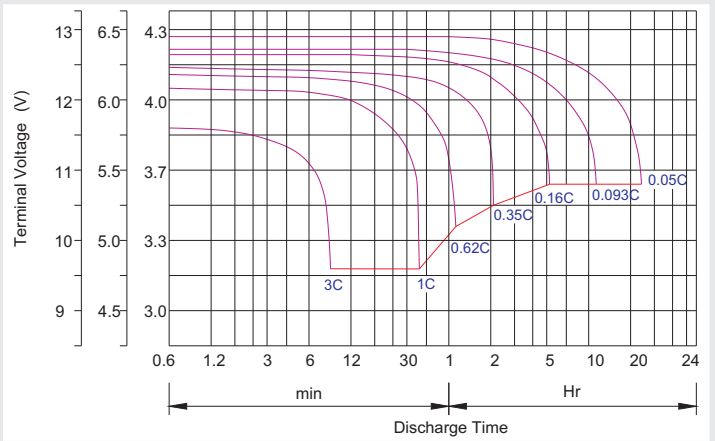

Capacity Factors With Different Temperature

Battery Type		-20°C	-10°C	0°C	5°C	10°C	20°C	25°C	30°C	40°C	45°C
GEL Battery	6V&12V	50%	70%	83%	85%	90%	98%	100%	102%	104%	105%
	2V	60%	75%	85%	88%	92%	99%	100%	103%	105%	106%
AGM Battery	6V&12V	46%	66%	76%	83%	90%	98%	100%	103%	107%	109%
	2V	55%	70%	80%	85%	92%	99%	100%	104%	108%	110%

Discharge Current VS. Discharge Voltage

Final Discharge Voltage V/cell	1.75V	1.70V	1.60V
Discharge Current (A)	(A) ≤ 0.2C	0.2C < (A) < 1.0C	(A) ≥ 1.0C

Charge the batteries at least once every six months, if they are stored at 25°C.

Charging Method:

Constant Voltage	-0.2Cx2h+2.4~2.45V/Cellx24h, Max. Current 0.3CA
Constant Current	-0.2Cx2h+0.1CAx12h
Fast	-0.2Cx2h+0.3CAx4.0h

Maintenance & Cautions

Float Service:
※ Every month, recommend inspection every battery voltage.
※ Every three months, recommend equalization charge for one time.
Equalization charge method:
Discharge: 100% rate capacity discharge.
Charge: Max. current 0.3CA, constant voltage 2.4-2.45V/Cell charge 24h.
※ Effect of temperature on float charge voltage: -3mV/°C/Cell.
※ Length of service life will be directly affected by the number of discharge cycles, depth of discharge, ambient temperature and charging voltage.

