

# SMW5PMPT

## WEDGE HOUSINGS



Weatherproof pole and wall mount wedge housings. IP66 Outdoor wedge housings for high security applications where corrosion resistance and mechanical strength are required.

The SMW5PMPT & SMW5PMPTSS are attractive, weatherproof enclosures constructed from either powder coated zinc plated steel or stainless steel. The housings pan tilt feature allows for a wide range of camera adjustments for different angles of view.

The enclosures are also highly vandal, corrosive and tamper resistant.

### OPTIONS

Omron tamper switch and mercury vibration switch are available as an option. Fixed angle pole top adaptor, heater high security locking system (bi-lock), wall bracket.

### APPLICATIONS

Car parks, under eaves, railway platforms, tunnels, pole mount, wall mount and walkways. Ideal weatherproof general purpose enclosure.

### SPECIFICATIONS

#### Construction

SMW5PMPT- 2.5mm zinc plated steel  
SMW5PMPTSS- 2.0mm 216 grade stainless steel.

#### Finish

SMW5PMPT- Mossvale sands (light beige) polyester powder coat.  
SMW5PMPTSS- White polyester powder coat.

#### Lens

6.0mm polycarbonate.

#### Access

4 x 6.0mm stainless steel security screws plus one Selectrix coin keylock as standard. Optional bi-lock high security key lock.

#### Cable Entry

2 x 20mm entries.

#### Max. Camera Size

265mm.

#### Weight

SMW5PMPT- 8.44kg.  
SMW5PMPTSS- 7.40kg.

### SMW5PMPT & SMW5PMPTSS

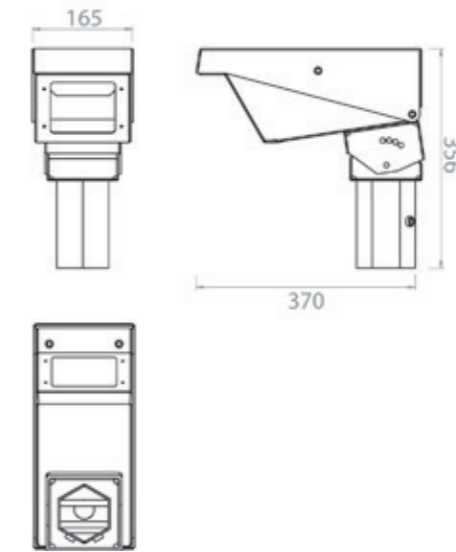

PART NUMBER	DESCRIPTION
SMW5PMPT	Adjustable pan & tilt weatherproof pole top wedge housing to suit 76.1mm maximum pole diameter.
SMW5PMPTSS	Adjustable pan & tilt weatherproof pole top housing to suit 76.1mm maximum pole diameter. Stainless steel construction.
HTR	Heater thermostat to suit all SMW5 housings.
TSW SMW5	Tamper switch to suit all SMW5 housings.
BILOCK	High security locking system to suit all SMW5 housings.