

# ECO ENVIRONMENTAL HOUSING



IP66 Outdoor camera housing for general purpose applications.

The ECO housing is designed to accommodate 1/4" to 1/3" CCD cameras fitted with fixed and zoom lenses. The camera lens combination, up to the recommended maximum length, allows at least 100mm clear space behind the camera for connections.

The pivoting lid swings clear of the lens to allow camera access and set up with the cover open. In this design the installer has full access to the sides, top and rear of the camera and lens. The camera is mounted on a clamped plate for fast install and removal.

## OPTIONS

A pole mount adaptor, tamper switch, demister heater and fan are optional with the ECO housing. ECO is also available in powder coated zinc anneal (ECO) for economy and powder coated 304 stainless steel (ECOSS) finish for corrosive environments. Comes complete with manual pan tilt and wall bracket.

## APPLICATIONS

Mounted off poles, building walls or in factories. The ideal economical robust general purpose camera housing.

## SPECIFICATIONS

### Construction

ECO- 1.2mm 1.6mm & 2.0mm zincanneal  
ECOSS- 1.2mm & 1.6mm stainless steel.

### Finish

ECO- Mossvale sands (light beige) polyester powder coat.  
ECOSS- White polyester powder coat.

### Lens

4.8mm arris edged glass.

### Cable Entry

3 x 20mm entries, two in the base and one positioned at the rear of the housing.

### Access

3 x 6mm pan head screws.

### Electrical

Optional heater thermostat 24 VAC 50Hz 11watts. Fan 24VAC 50Hz 3.2 watts. Alternate voltages available.

### Max. Camera Size

220mm (L) x 115mm (W) x 86mm (H).

### Weight

ECO- 4.5kg  
ECOSS- 4.7kg

## ECO& ECOSS

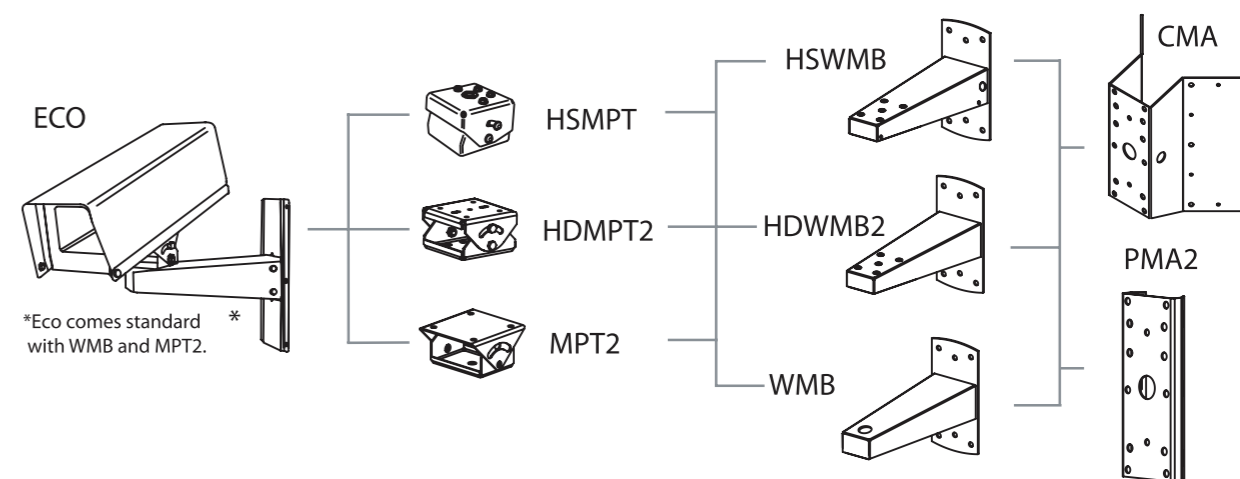
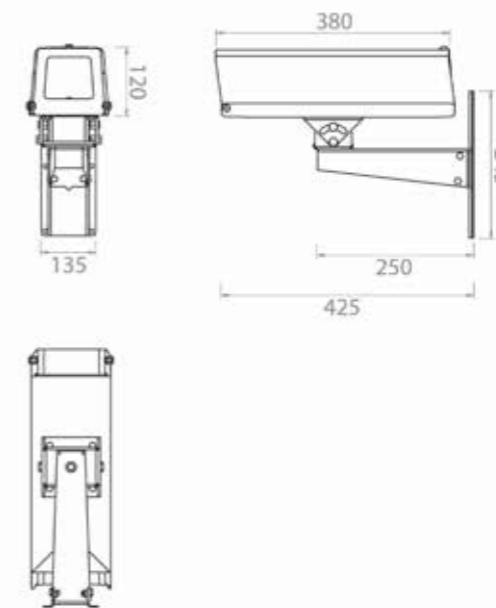

ENVIRONMENTAL

| PART NUMBER | DESCRIPTION   |
|-------------|---|
| ECO         | External housing complete with wall mount bracket and manual pan tilt bracket.        |
| ECOSS       | Stainless steel housing complete with wall mount bracket and manual pan tilt bracket. |
| ECOSEC      | 3 x M6 security screws and allen key for added security.                              |
| FANHTR      | Fan heater to suit ECO & LPAR series housings.  |
| HTR         | Heater thermostat to suit ECO & LPAR400 housings.                                     |
| TSW         | Tamper switch to suit ECO & LPAR series housings.                                     |

**SEE Security**  
3 Darnick Street  
Underwood QLD 4119

P 07 3841 4255  
E admin@seesecurity.com.au

www.seesecurity.com.au