

# MEM4400

## Mechanical Electro Magnet

### Introduction:

The patented MEM4400 Mechanical Electro Magnetic locking device is design for securing automatic sliding door mechanisms. The MEM device has a holding force of 4000N and is designed to be installed within the track of Automatic Sliding Doors. A standard L- Shaped mounting bracket is supplied with the MEM Armature Plate to be connected to the sliding element of the sliding door mechanism. The brackets might have to be customized depending on the brand and type of sliding door mechanism.

### Wiring and Power input requirements:

#### MEM Lock Wiring from the PCB to the Lock:

MEM Power Input: **RED (+); BLACK (-)**

EW Sensor Output: **WHITE (NC), BROWN (C), GRAY (NO)**, 30 VDC, 0.2 A Max.

#### PCB Connection from the Access Control System:

Power Input: +12~24 VDC(12V/0.28A, 24V/0.14A)

DSS Sensor Input: Normally Closed. In the absence of a sensor, place a link across DSS terminal.

MEM Lock Power Output: Connect to MEM Power Input. Connect L+ to **RED (+)**;  
Connect L- to **BLACK (-)**

Exit Input: Normally Open.

Auto Door Control Output: Normally Open. Relay Output. Connect to Auto Door Control Panel Input.

Alarm Relay Timer Input: Normally Open. Short to active the C/NC/NO Alarm Relay Output. Connect to EW Sensor Output **BROWN** and **GRAY**.

Alarm Relay Output: C/NC/NO Relay Output. 0 ~ 30 Seconds Delay Timer.

### Product Dimensions:

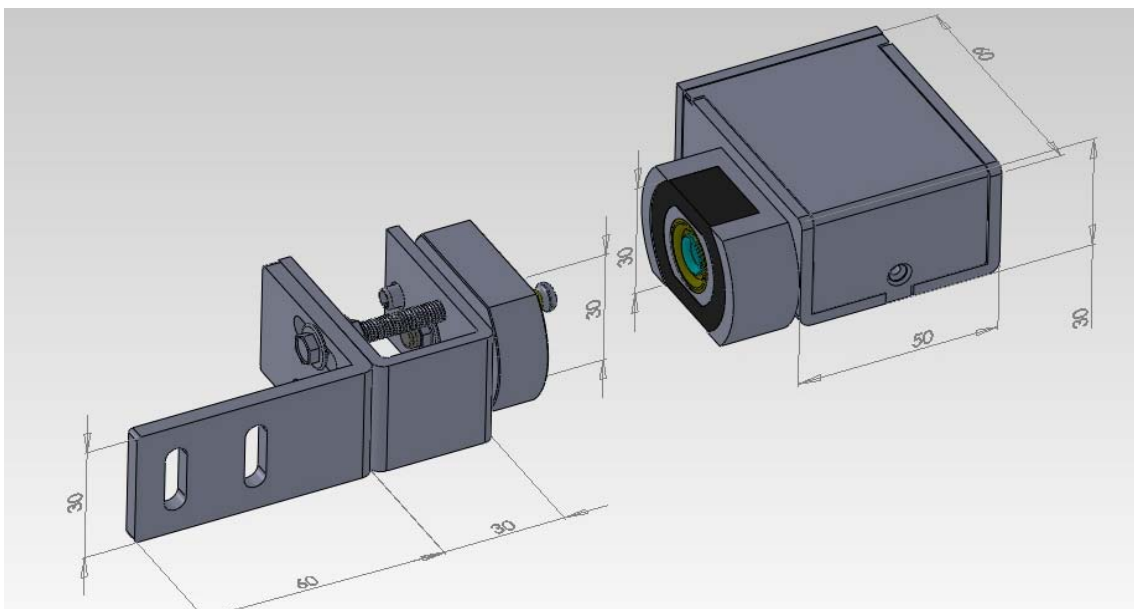

## Installation procedure:

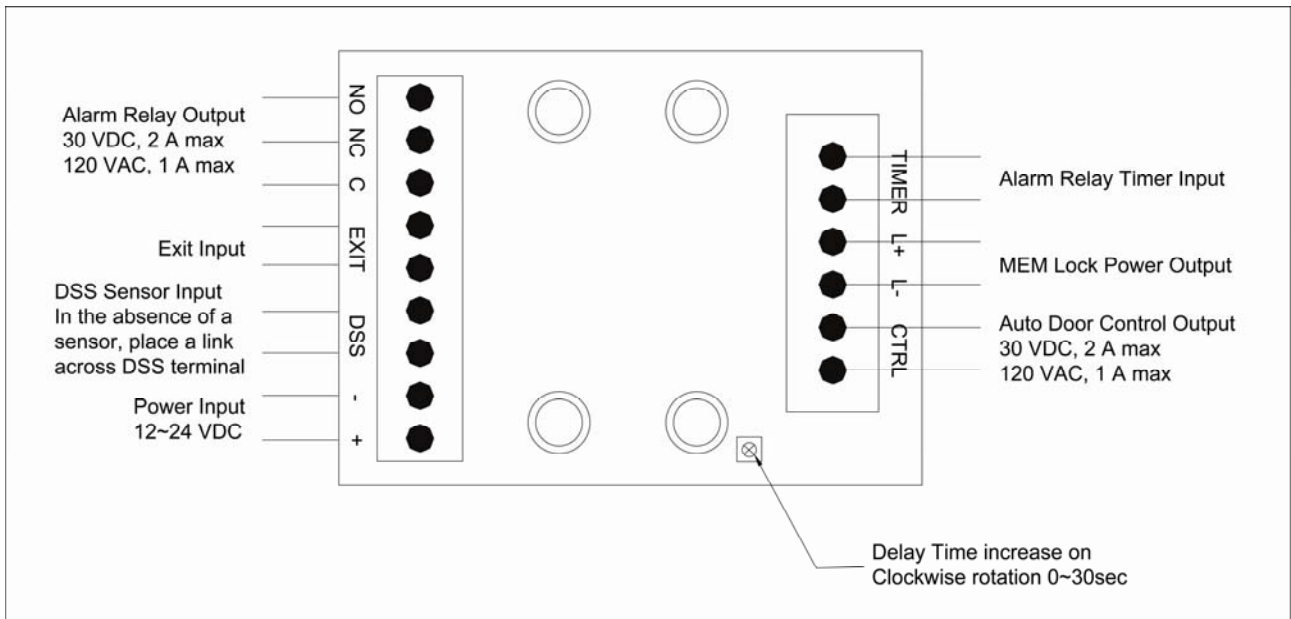

1. Adjust "L" fixing bracket to armature plate with U bracket on the track.
2. Fix "L" fixing bracket and armature plate with U bracket to door supporting roller bracket.
3. Fix MEM Magnetic lock & bracket to the sliding door track.
4. Ensure MEM armature plate locking pin is correctly aligned to couple with the MEM magnet center hole.
5. Do not over tighten the armature plate against roller carriage. The armature plate must remain floating to allow correct alignment with the magnet face or the magnetic lock will lose holding force without this alignment.
6. Connect power and test operation.

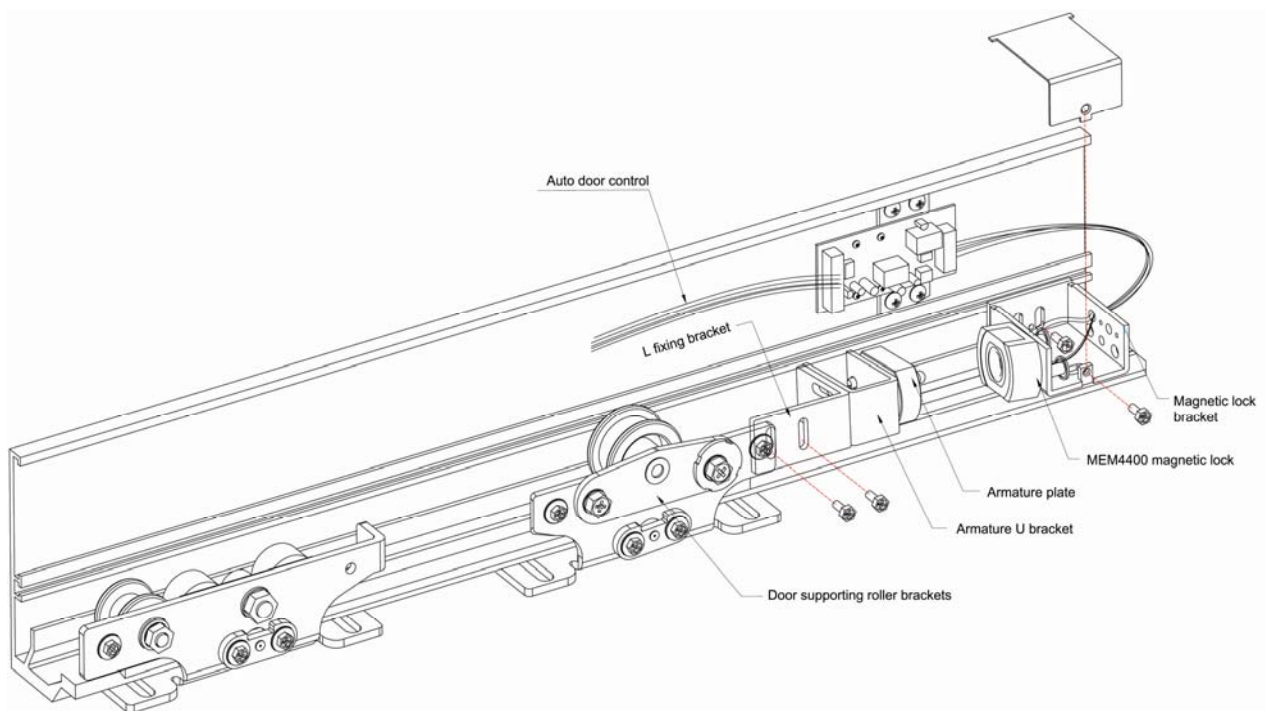

## Functions:

### **A. Automatic door Open to Close sequence:**

When the Auto Door returns to closed position the MEM lock detects the armature plate and after a delay of 0.5 seconds, to allow the Auto Door Control Relay Output to deactivate, the MEM automatically locks.

### **B. Automatic door Close to Open sequence:**

When the system receives an "Exit" input the MEM releases and after a 0.5 second delay the Auto Door Control Relay Output (NO/NC changeover contacts) is activated allowing the door to open.

### **C. Security Alarm feature:**

The MEM lock is provided with the unique and patented "early warning" security monitoring alarm. If an attempted forced entry occurs the MEM will immediately activate the alarm relay output for either local (audible/visible) or remote indication. The alarm can be adjusted from 0 to 30 seconds by the potentiometer located on the circuit board.



**CENTRAL SECURITY DISTRIBUTION**

**1300 319 499**  
**csd.com.au**

**VIC: Mulgrave, Tullamarine   NSW: Seven Hills, Waterloo   ACT: Fyshwick   QLD: Loganholme   SA: Marleston   WA: Balcatta**